

Ball Spline Types LT and LF

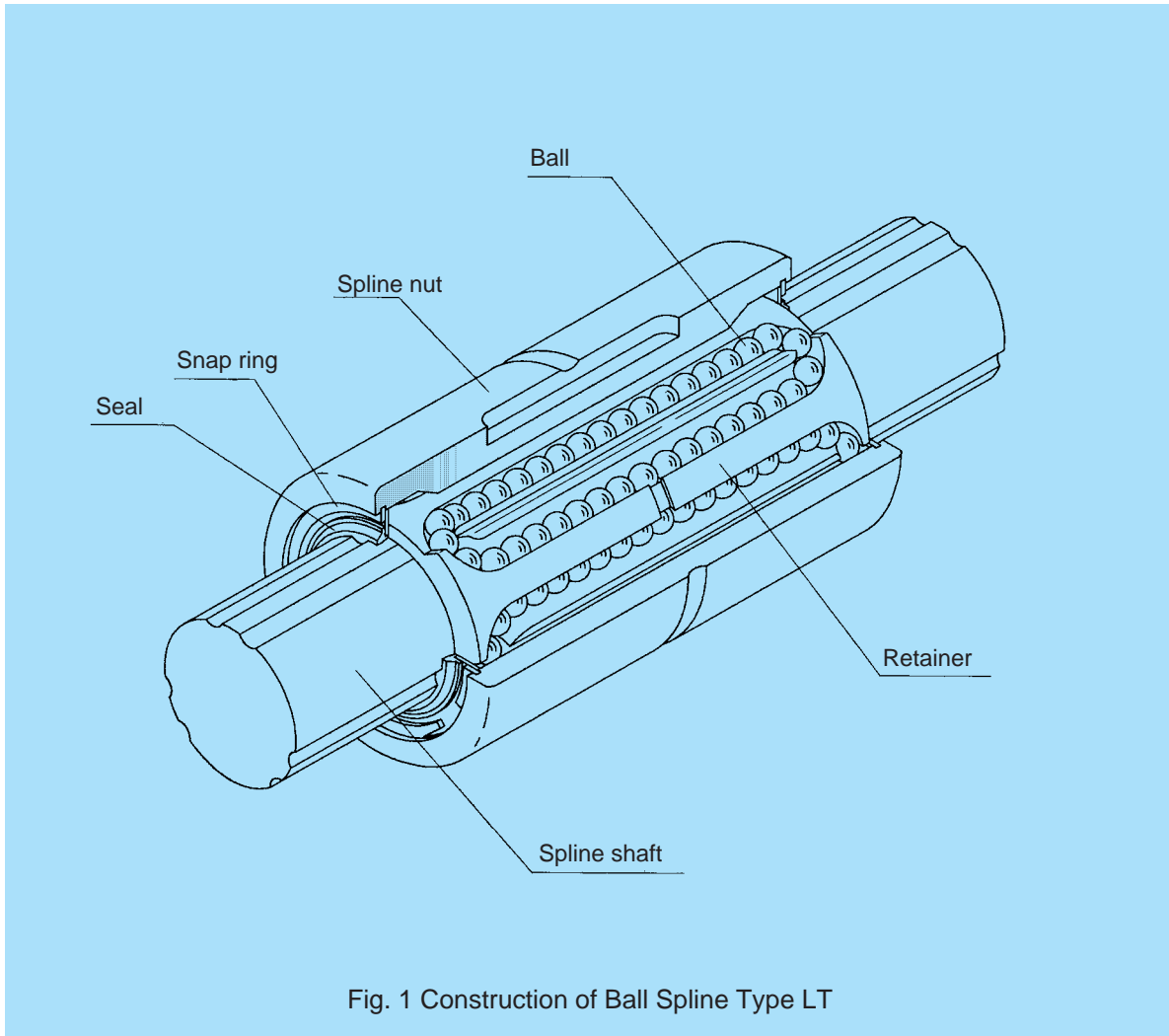

Construction and Features

Ball Spline types LT and LF have four or six trains of load-bearing balls to hold two or three crests on the spline shaft from both sides, so that an appropriate preload is applied without trouble. The balls are held in place by the retainer, which is made of special synthetic resin and built into the interior of the spline nut. The retainer causes the balls to circulate in line and prevents them from falling off if the spline shaft is removed.

High load-carrying capability

The raceways are formed into circular-arc grooves with a radius approximately the same as that of the ball, and are designed to permit angular contact. Types LT and LF therefore have a high load-carrying capability in both the radial and torque-applying directions.

Zero angular backlash

The preloaded angular-contact design, in which two trains of balls arranged opposite another hold a crest on the spline shaft at a contact angle of 20° , reduces the angular backlash in the rotational direction to zero and increases rigidity.

High rigidity

A wide contact angle and an appropriate level of preload combine to provide high torque and moment rigidity.

Simple assembly

Balls do not fall off if the spline nut is removed from the spline shaft. As a result, assembly, maintenance, and checking are simple.

(This does not apply to type LT4 or 5.)

Types and Features

Cylindrical Ball Spline Type LT

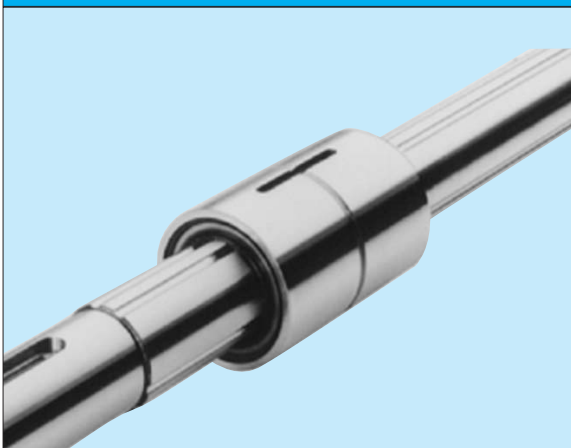

The spline nut is of a straight cylindrical shape. When it is necessary to apply a torque, insert a key into the keyway. Type LT is the most compact of all Ball Spline types.

Flanged Ball Spline Type LBF



The spline nut can be attached to the housing via the flange, making assembly simple. It is most suitable where the housing may deform if a keyway is cut thereon, and where the housing width is limited. Knock pins that can be driven into the flange completely eliminate the angular backlash that occurs in fitting part.

Precision Solid Spline Shaft (standard type)

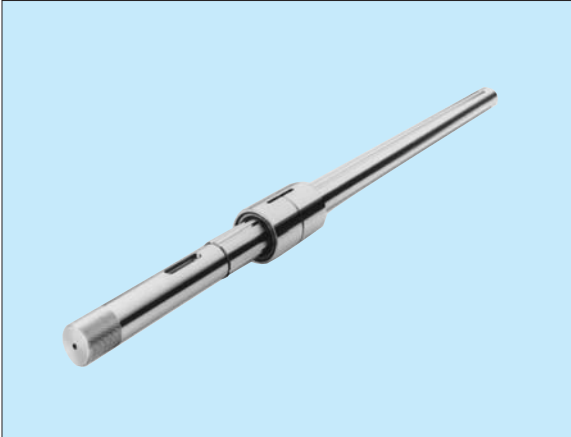

The raceways of the spline shaft are cut into the shaft to a high degree of precision. A spline nut is attached to the resulting spline shaft.

Special Spline Shaft



A shaft with a greater diameter at its ends or mid-point can be produced upon request, by machining it to the required spline shape.

Hollow Spline Shaft (Type K)



(Thick wall)

Hollow Spline Shaft (Type N)

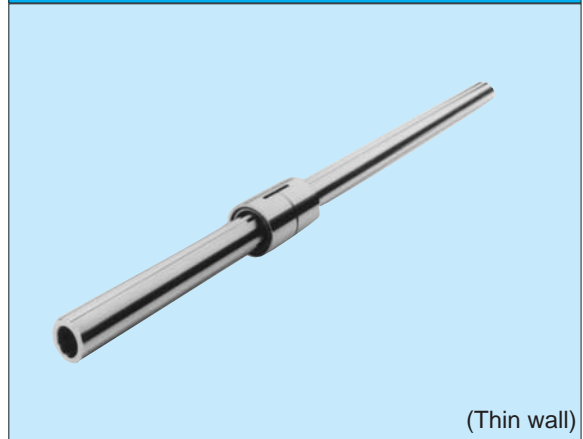

(Thin wall)

This type is made hollow through cold drawing, to enable it to accommodate pipes and wires and vent air, or to reduce its weight.

Standard Ball Spline (standard off-the-shelf item)

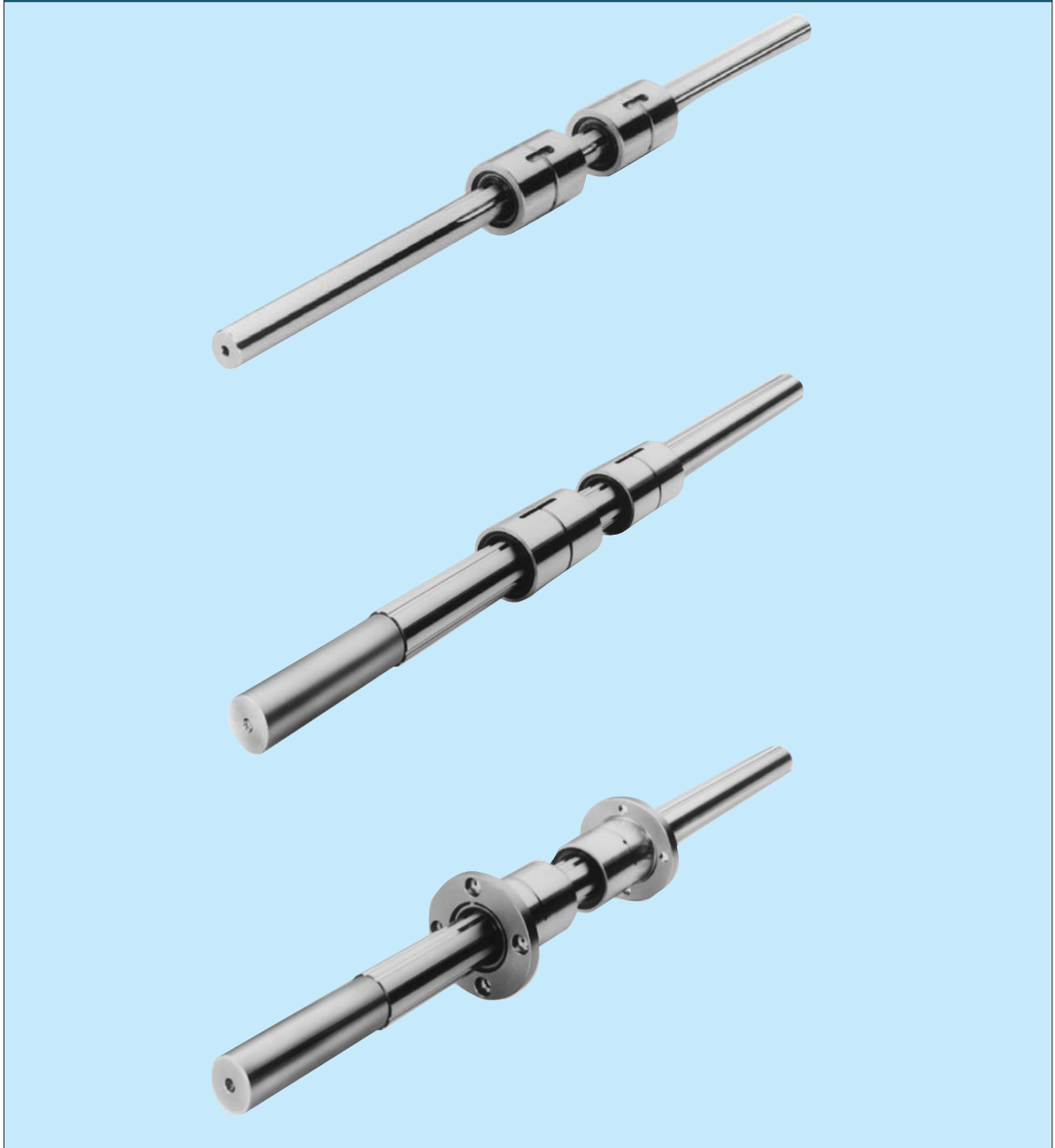

B-II

Precision-ground spline shafts of various standardized lengths (LT6 through LT50) and a variety of spline nuts can be freely combined to your specifications, enabling quick delivery at a low price. For the standards, see page B-80.

Spline-Shaft Strength

See page B-13.

Clearance in the Rotational Direction

The clearance of the Ball Spline in the rotational direction significantly affects the rigidity and precision of the spline nut.

It is very important, therefore, to determine the appropriate clearance for the intended uses. As repeated swiveling and reciprocal linear motions cause heavy vibration and impact, preloading the system drastically improves its service life and accuracy.

We will determine the optimum clearance for your operating conditions. Please contact us.

Table 1 presents the clearances in the rotational direction for Ball Spline types LT and LF.

Accuracy Standards

See page B-33.

| | | Operating conditions |
|---------------------------------------|--------|---|
| Clearance in the rotational direction | CM | <ul style="list-style-type: none"> • High rigidity is required; vibration and impact are heavy. • Moment loads must be borne by a single spline nut. |
| | CL | <ul style="list-style-type: none"> • Overhang loads and moments are applied. • Highly reproducible accuracy is required. • Alternate loads are applied. |
| | Normal | <ul style="list-style-type: none"> • Smooth movement should be achieved with only a low magnitude of force. • Torque is continually applied in a given direction. |

Table 1 Clearance in the Rotational Direction

Unit: μm

| Nominal shaft diameter | Symbol | Normal | Light preload | Medium preload |
|------------------------|---------|-----------|---------------|----------------|
| | | No symbol | CL | CM |
| 4 | | | | / |
| 5 | | | | |
| 6 | | | | |
| 8 | -2 ~ +1 | -6 ~ -2 | | |
| 10 | | | | |
| 13 | | | | |
| 16 | | | | -9 ~ -5 |
| 20 | | | | |
| 25 | -3 ~ +2 | -10 ~ -4 | | -14 ~ -8 |
| 30 | | | | |
| 40 | -4 ~ +2 | -16 ~ -8 | | -22 ~ -14 |
| 50 | | | | |
| 60 | -5 ~ +2 | -22 ~ -12 | | -30 ~ -20 |
| 80 | | | | |
| 100 | -6 ~ +3 | -26 ~ -14 | | -36 ~ -24 |

Note: For normal clearance, do not append any symbol to a model number. For medium and light preloads, append "CM" or "CL". (For model-number coding, see page B-78.)

Housing Inner-Diameter Tolerance

See page B-37.

Spline Shaft

Spline-shaft cross-sectional shape and outer-diameter tolerance

For Ball Spline types LT and LF, spline shafts can be provided upon request. When requesting an estimate or placing an order, specify the spline-shaft cross-sectional shape.

Table 2 presents the spline-shaft minor diameters and tolerances for the standard spline-shaft outer diameters.

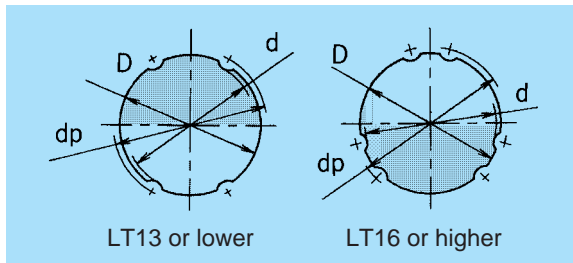

Table 2 Spline-Shaft Cross-Sectional Shape

Unit : mm

| Nominal shaft diameter | Minor diameter d | Outer diameter D | Outer-diameter tolerance |
|------------------------|------------------|------------------|--------------------------|
| 4 | 3.5 | 4 | 0 -0.012 |
| 5 | 4.5 | 5 | |
| 6 | 5.0 | 6 | |
| 8 | 7.0 | 8 | 0 -0.015 |
| 10 | 8.5 | 10 | |
| 13 | 11.5 | 13 | 0 -0.018 |
| 16 | 14.5 | 16 | |
| 20 | 18.5 | 20 | 0 -0.021 |
| 25 | 23.0 | 25 | |
| 30 | 28.0 | 30 | |
| 40 | 37.5 | 40 | 0 -0.025 |
| 50 | 46.5 | 50 | |
| 60 | 56.5 | 60 | 0 -0.030 |
| 80 | 75.5 | 80 | |
| 100 | 95.0 | 100 | 0 -0.035 |

Table 3 Ball Center-to-Center Shaft Diameter

Unit mm

| Nominal shaft diameter | 4 | 5 | 6 | 8 | 10 | 13 | 16 | 20 | 25 | 30 | 40 | 50 | 60 | 80 | 100 |
|------------------------|-----|-----|---|-----|------|------|------|------|------|------|------|------|------|------|-------|
| dp | 4.6 | 5.7 | 7 | 9.3 | 11.5 | 14.8 | 17.8 | 22.1 | 27.6 | 33.2 | 44.2 | 55.2 | 66.3 | 87.9 | 109.5 |

Hollow-spline-shaft inner diameter

For Ball Spline types LT and LF, the hollow spline shafts shown in Table 4 are available as standard components. They are lightweight and can be used as a hydropneumatic passage.

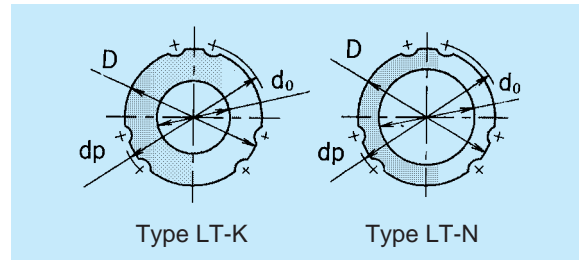

Table 4 Standard Hollow-Spline-Shaft Dimensions

Unit: mm

| Nominal shaft diameter | Outer diameter D | Type K | | Type N | |
|------------------------|------------------|--------------------|-----------|--------------------|-----------|
| | | Hollow diameter do | Mass kg/m | Hollow diameter do | Mass kg/m |
| 6 | 6 | 2.5 | 0.20 | - | - |
| 8 | 8 | 3.0 | 0.35 | - | - |
| 10 | 10 | 4.0 | 0.52 | - | - |
| 13 | 13 | 5.0 | 0.95 | - | - |
| 16 | 16 | 7 | 1.3 | 11 | 0.8 |
| 20 | 20 | 10 | 1.8 | 14 | 1.3 |
| 25 | 25 | 12 | 3.0 | 18 | 1.9 |
| 30 | 30 | 16 | 4.0 | 21 | 2.8 |
| 40 | 40 | 22 | 6.9 | 29 | 4.7 |
| 50 | 50 | 25 | 11.6 | 36 | 7.4 |
| 60 | 60 | 32 | 16.0 | - | - |
| 80 | 80 | 52.5 | 22.6 | - | - |
| 100 | 100 | 67.5 | 33.7 | - | - |

Note: The standard hollow spline shaft comes in two types, K and N. Specify the required type by appending "K" or "N" to the desired model number.

Length of incomplete spline portion in special spline-shaft

To obtain a spline-shaft end or mid-point diameter greater than the minor diameter (d), an incomplete spline portion is required to provide a recess under the grinding wheel. Table 5 shows the relationship between the incomplete spline length (S) and the flange diameter (D_0). This, however, does not apply to spline shafts with an overall length of 1,500 mm or more. For spline shafts with an overall length greater than 1,500 mm, contact us.

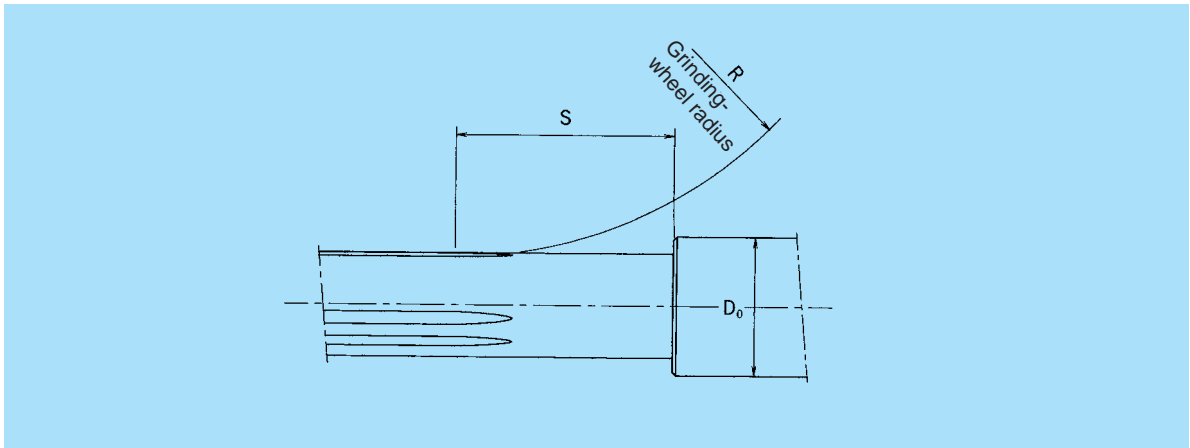

Table 5 Incomplete Spline Length: S

| Miniature type | | Unit: mm | | | | |
|--|----|----------|----|----|----|--|
| Nominal shaft diameter \ Flange diameter D_0 | 4 | 5 | 6 | 8 | 10 | |
| 4 | 13 | 20 | 24 | 31 | - | |
| 5 | - | 14 | 21 | 28 | 33 | |

| Standard type | | Unit: mm | | | | | | | | | | | | | | |
|--|----|----------|----|----|----|----|----|----|----|----|----|----|-----|-----|-----|-----|
| Nominal shaft diameter \ Flange diameter D_0 | 6 | 8 | 10 | 13 | 16 | 20 | 25 | 30 | 40 | 50 | 60 | 80 | 100 | 120 | 140 | 160 |
| 6 | 16 | 24 | 28 | 33 | - | - | - | - | - | - | - | - | - | - | - | - |
| 8 | - | 16 | 24 | 30 | 35 | - | - | - | - | - | - | - | - | - | - | - |
| 10 | - | - | 17 | 27 | 32 | 37 | - | - | - | - | - | - | - | - | - | - |
| 13 | - | - | - | 17 | 27 | 34 | 40 | - | - | - | - | - | - | - | - | - |
| 16 | - | - | - | - | 21 | 36 | 46 | 54 | - | - | - | - | - | - | - | - |
| 20 | - | - | - | - | - | 21 | 38 | 48 | 62 | - | - | - | - | - | - | - |
| 25 | - | - | - | - | - | - | 23 | 39 | 56 | 67 | - | - | - | - | - | - |
| 30 | - | - | - | - | - | - | - | 24 | 49 | 62 | 72 | - | - | - | - | - |
| 40 | - | - | - | - | - | - | - | - | 27 | 50 | 63 | 81 | - | - | - | - |
| 50 | - | - | - | - | - | - | - | - | - | 29 | 51 | 74 | 89 | - | - | - |
| 60 | - | - | - | - | - | - | - | - | - | - | 28 | 56 | 71 | 82 | - | - |
| 80 | - | - | - | - | - | - | - | - | - | - | - | 31 | 57 | 72 | 83 | - |
| 100 | - | - | - | - | - | - | - | - | - | - | - | - | 33 | 58 | 73 | 83 |

Accessories

Ball Spline type LT comes with one of the standard keys listed in Table 6.

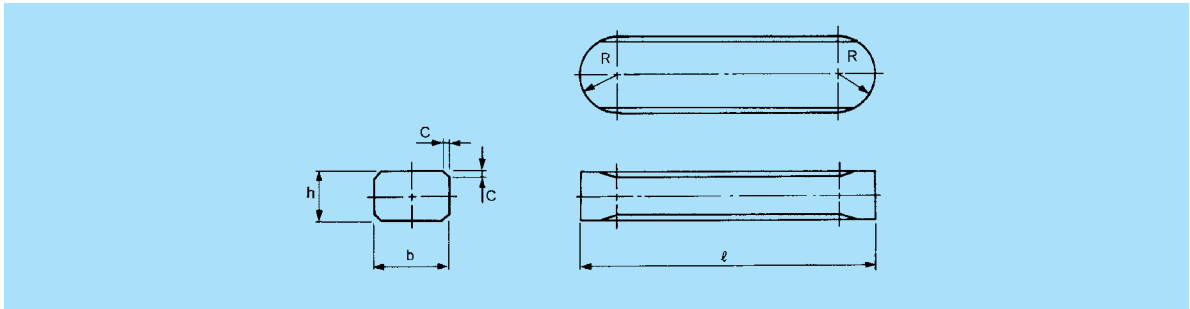

B-II

Table 6 Standard Key for LT

Unit: mm

| Model No. | Width b | | Height h | | Length <i>l</i> | | R | C | | |
|--------------|---------|------------------|------------------|----------------|-----------------|-----------------|-------------|-----|-------------|---|
| | | Tolerance (p7) | | Tolerance (h9) | | Tolerance (h12) | | | | |
| LT 4 | 2 | +0.016 +0.006 | 2 | 0 -0.025 | 6 | 0 -0.120 | 1 | 0.3 | | |
| LT 5 | 2.5 | | 2.5 | | 8 | 0 -0.150 | 1.25 | 0.5 | | |
| LT 6 LT 8 | 2.5 | | 2.5 | | 10.5 | 0 -0.180 | 1.25 | 0.5 | | |
| LT 10 | 3 | | 3 | | 13 | | 1.5 | | | |
| LT 13 | 3 | | 3 | | 15 | | 1.5 | | | |
| LT 16 | 3.5 | | 3.5 | | 17.5 | 1.75 | | | | |
| LT 20 | 4 | | 4 | | 29 | 0 -0.210 | 2 | | | |
| LT 25 | 4 | | +0.024 +0.012 | | 4 | 0 -0.030 | 36 | | 0 -0.250 | 2 |
| LT 30 | 4 | | | | 4 | | 42 | | 2 | |
| LT 40 | 6 | | | | 6 | | 52 | | 3 | |
| LT 50 | 8 | 7 | | 58 | 0 -0.300 | | 4 | | | |
| LT 60 | 12 | +0.036 +0.018 | 8 | 0 -0.036 | 67 | 0 -0.300 | 6 | | 0.8 | |
| LT 80 | 16 | | 10 | | 76 | | 8 | | | |
| LT 100 | 20 | | 13 | | 110 | | 0 -0.350 | 10 | | |

Model-Number Coding

The coding of Ball Spline model numbers is as specified below.

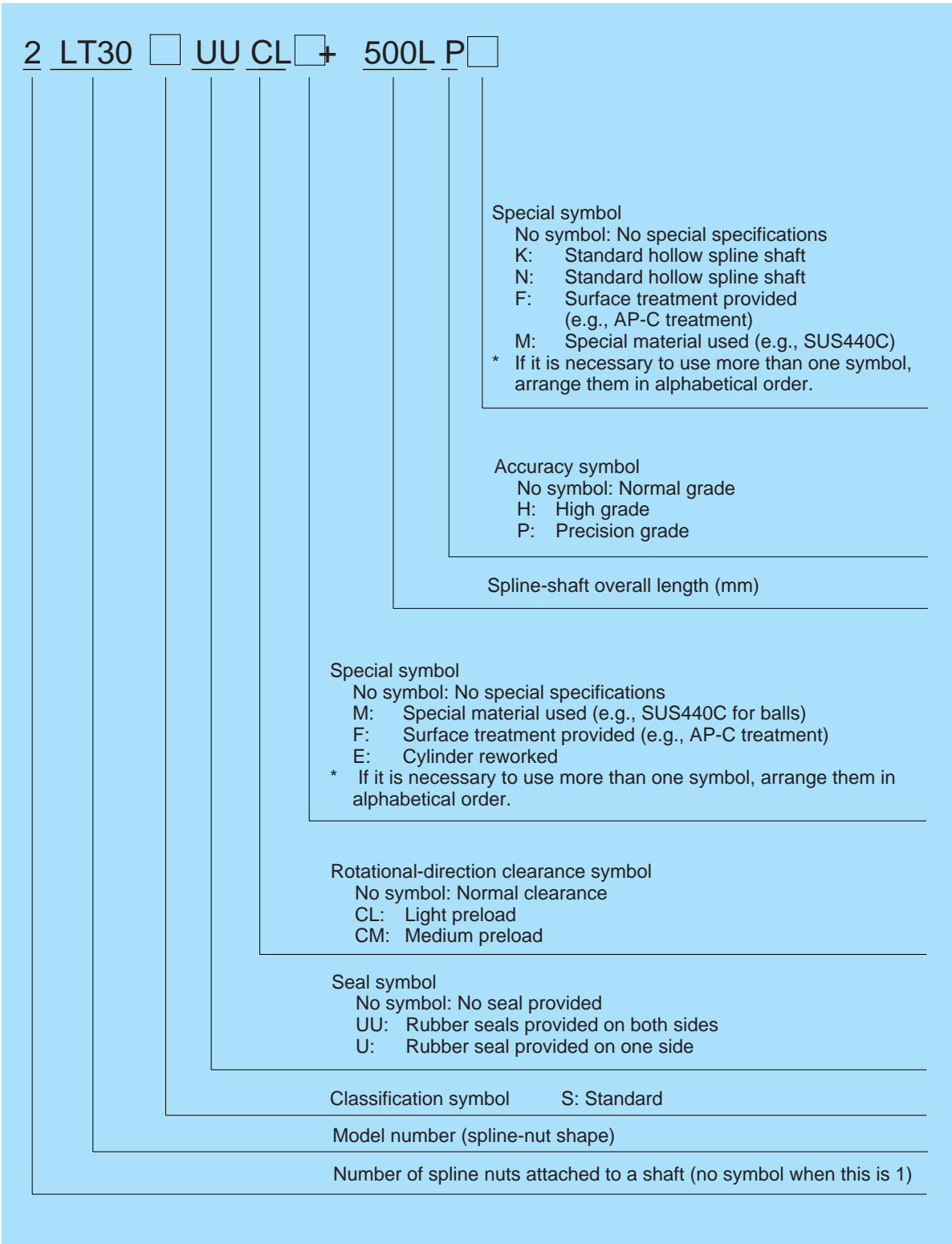

Standard Ball Spline Type LT

(Standard off-the-shelf item)

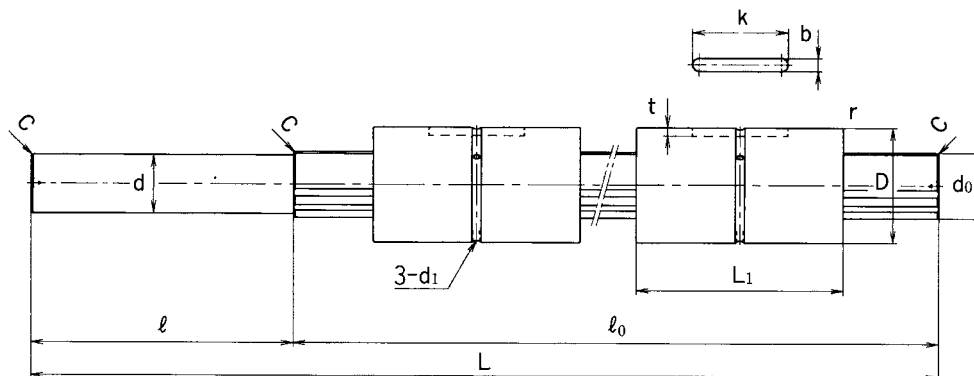

| Model No. | Spline-nut dimensions | | | | | | | | | |
|---------------------|-----------------------|-------------|--------------------------|-----------|-------------------|----------------------------|------|-----|----------------------------|----------------------|
| | Outer diameter D | Tolerance | Length L ₁ | Tolerance | Keyway dimensions | | | r | Oil hole d ₁ | d ₀ h7 |
| | | | | | b H8 | t ^{+0.05} 0 | k | | | |
| LT 6 S 2LT 6 S | 14 | 0 -0.011 | 25 | 0 -0.2 | 2.5 | 1.2 | 10.5 | 0.5 | 1 | 6 |
| LT 8 S 2LT 8 S | 16 | | 25 | | 2.5 | 1.2 | 10.5 | 0.5 | 1.5 | 8 |
| LT 10 S 2LT 10 S | 21 | 0 -0.013 | 33 | | 3 | 1.5 | 13 | 0.5 | 1.5 | 10 |
| LT 13 S 2LT 13 S | 24 | | 36 | | 3 | 1.5 | 15 | 0.5 | 1.5 | 13 |
| LT 16 S 2LT 16 S | 31 | | 50 | | 3.5 | 2 | 17.5 | 0.5 | 2 | 16 |
| LT 20 S 2LT 20 S | 35 | 0 -0.016 | 63 | | 0 -0.3 | 4 | 2.5 | 29 | 0.5 | 2 |
| LT 25 S 2LT 25 S | 42 | | 71 | 4 | | 2.5 | 36 | 0.5 | 3 | 25 |
| LT 30 S 2LT 30 S | 47 | | 80 | 4 | | 2.5 | 42 | 0.5 | 3 | 30 |
| LT 40 S 2LT 40 S | 64 | 0 -0.019 | 100 | 6 | | 3.5 | 52 | 0.5 | 4 | 40 |
| LT 50 S 2LT 50 S | 80 | | 125 | 8 | 4 | 58 | 1 | 4 | 50 | |

Notes:

- The basic torque and load ratings are for single-spline nut use.
- Only the spline section is induction-hardened to a surface hardness of HRC58 through HRC64.
- Both the rotational-direction clearance and accuracy grade are normal.
- If a model with seals is required, please specify.

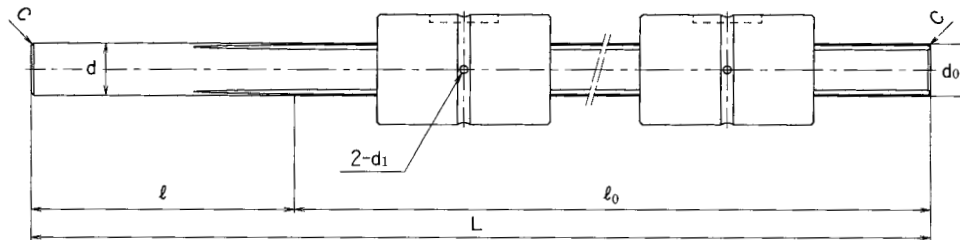

LT13S or lower

Unit: mm

| Spline-shaft dimensions | | | | | Basic torque rating | | Basic load rating (radial) | | | |
|-------------------------|---|--------------|-------------------------|---------------------------|---------------------|---------|----------------------------|-------------|----------|------|
| d | Tolerance | R | Length L(l_0) | | Chamfer C | C kN | C_0 kN | C_T Nm | C_{OT} | |
| | | | | | | | | | | |
| 6 | $\begin{matrix} 0 \\ -0.012 \end{matrix}$ | 100 | 150(50) | 200(100) | 0.5 | 1.18 | 2.16 | 0.98 | 1.96 | |
| 8 | $\begin{matrix} 0 \\ -0.015 \end{matrix}$ | 100 | 150(50) | 200(100) | 250(150) | 0.5 | 1.47 | 2.55 | 1.96 | 2.94 |
| 10 | | 100 | 200(100) | 300(200) | | 0.5 | 2.84 | 4.90 | 3.92 | 7.84 |
| 13 | $\begin{matrix} 0 \\ -0.018 \end{matrix}$ | 100 | 200(100) | 300(200) | 400(300) | 0.5 | 3.53 | 5.78 | 5.88 | 10.8 |
| 14.3 | $\begin{matrix} +0.1 \\ 0 \end{matrix}$ | 100 | 200(100) | 300(200) | 400(300) | 0.5 | 7.06 | 12.6 | 31.4 | 34.3 |
| 17.8 | | 100 | 300(200) 600(500) | 400(300) | 500(400) | 0.5 | 10.2 | 17.8 | 56.9 | 55.9 |
| 22.8 | | 100 | 300(200) 600(500) | 400(300) 800(700) | 500(400) | 0.5 | 15.2 | 25.8 | 105 | 103 |
| 27.8 | | 100 | 400(300) 700(600) | 500(400) 1100(1000) | 600(500) | 0.5 | 20.5 | 34.0 | 171 | 148 |
| 36.3 | | 100 | 500(400) 1100(1000) | 700(600) 1600(1500) | 900(800) | 1 | 37.8 | 60.5 | 419 | 377 |
| 45.3 | | 100 (200) | 600(500) 1700(1600) | 1100(1000) *2200(2000) | 1300(1200) | 1 | 60.9 | 94.5 | 842 | 769 |

- The spline nut accommodates a synthetic resin retainer.
- For model-number coding, see page B-78.
- For lengths marked with a “*”, dimension l is 200 mm.

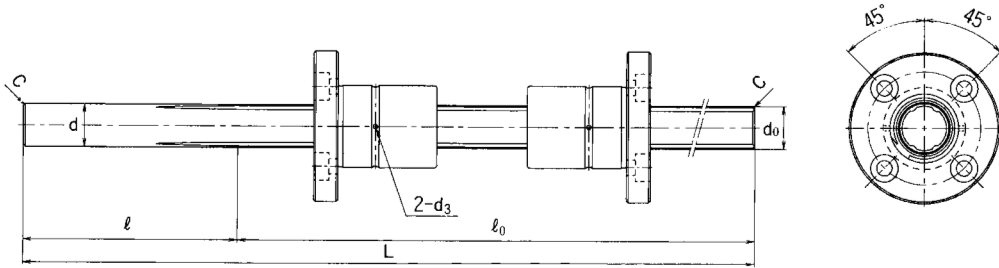

LF13S or lower

Unit: mm

| d | Tolerance | l | Spline-shaft dimensions | | | Chamfer C | Basic torque rating | | Basic load rating (radial) | |
|------|---|-------|-------------------------------|---------------------------|-------------|--------------|---------------------|----------------------|----------------------------|-----------------------|
| | | | Length L (l ₀) | | | | C kN | C ₀ kN | C _T Nm | C _{0T} Nm |
| 6 | $\begin{matrix} 0 \\ -0.012 \end{matrix}$ | 100 | 150 (50) | 200 (100) | | 0.5 | 1.18 | 2.16 | 0.98 | 1.96 |
| 8 | $\begin{matrix} 0 \\ -0.015 \end{matrix}$ | 100 | 150 (50) | 200 (100) | 250 (150) | 0.5 | 1.47 | 2.55 | 1.96 | 2.94 |
| 10 | | 100 | 200 (100) | 300 (200) | | 0.5 | 2.84 | 4.90 | 3.92 | 7.84 |
| 13 | $\begin{matrix} 0 \\ -0.018 \end{matrix}$ | 100 | 200 (100) | 300 (200) | 400 (300) | 0.5 | 3.53 | 5.78 | 5.88 | 10.8 |
| 14.3 | $\begin{matrix} +0.1 \\ 0 \end{matrix}$ | 100 | 200 (100) | 300 (200) | 400 (300) | 0.5 | 7.06 | 12.6 | 31.4 | 34.3 |
| 17.8 | | 100 | 300 (200) 600 (500) | 400 (300) | 500 (400) | 0.5 | 10.2 | 17.8 | 56.9 | 55.9 |
| 22.8 | | 100 | 300 (200) 600 (500) | 400 (300) 800 (700) | 500 (400) | 0.5 | 15.2 | 25.8 | 105 | 103 |
| 27.8 | | 100 | 400 (300) 700 (600) | 500 (400) 1100 (1000) | 600 (500) | 0.5 | 20.5 | 34.0 | 171 | 148 |
| 36.3 | | 100 | 500 (400) 1100 (1000) | 700 (600) 1600 (1500) | 900 (800) | 1 | 37.8 | 60.5 | 419 | 377 |
| 45.3 | | 100 | 600 (500) | 1100 (1000) | 1300 (1200) | 1 | 60.9 | 94.5 | 842 | 769 |
| | | (200) | 1700 (1600) | *2200 (2000) | | | | | | |

- For model-number coding, see page B-78
- In single-spline-nut use, the flange is pointed toward the spline-shaft terminal (to the left in the dimension drawing).
- For lengths marked with a “*”, dimension l is 200 mm.

Type LT

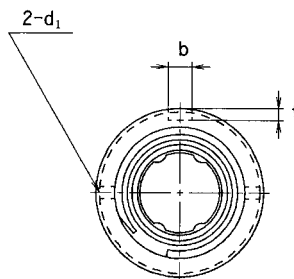

LT13 or lower

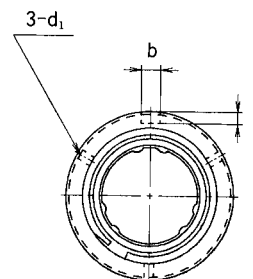

LT16 or higher

| Model No. | Spline-nut dimensions | | | | | | | | | |
|------------|-----------------------|---|-------------|---|---|---|------|-----|----------------------|---|
| | Outer diameter D | Tolerance | Length L | Tolerance | b H8 | Keyway dimensions $\begin{matrix} t \\ +0.05 \\ 0 \end{matrix}$ | l | r | Oil hole d_1 | |
| Note) LT 4 | 10 | $\begin{matrix} 0 \\ -0.009 \end{matrix}$ | 16 | $\begin{matrix} 0 \\ -0.2 \end{matrix}$ | 2 | 1.2 | 6 | 0.5 | - | |
| Note) LT 5 | 12 | $\begin{matrix} 0 \\ -0.011 \end{matrix}$ | 20 | | 2.5 | 1.2 | 8 | 0.5 | - | |
| LT 6 | 14 | | 25 | | 2.5 | 1.2 | 10.5 | 0.5 | 1 | |
| LT 8 | 16 | | 25 | | 2.5 | 1.2 | 10.5 | 0.5 | 1.5 | |
| LT 10 | 21 | $\begin{matrix} 0 \\ -0.013 \end{matrix}$ | 33 | | 3 | 1.5 | 13 | 0.5 | 1.5 | |
| LT 13 | 24 | | 36 | | 3 | 1.5 | 15 | 0.5 | 1.5 | |
| LT 16 | 31 | | 50 | | 3.5 | 2 | 17.5 | 0.5 | 2 | |
| LT 20 | 35 | $\begin{matrix} 0 \\ -0.016 \end{matrix}$ | 63 | | $\begin{matrix} 0 \\ -0.3 \end{matrix}$ | 4 | 2.5 | 29 | 0.5 | 2 |
| LT 25 | 42 | | 71 | 4 | | 2.5 | 36 | 0.5 | 3 | |
| LT 30 | 47 | | 80 | 4 | | 2.5 | 42 | 0.5 | 3 | |
| LT 40 | 64 | $\begin{matrix} 0 \\ -0.019 \end{matrix}$ | 100 | 6 | | 3.5 | 52 | 0.5 | 4 | |
| LT 50 | 80 | | 125 | 8 | | 4 | 58 | 1.0 | 4 | |
| LT 60 | 90 | $\begin{matrix} 0 \\ -0.022 \end{matrix}$ | 140 | $\begin{matrix} 0 \\ -0.4 \end{matrix}$ | | 12 | 5 | 67 | 1.0 | 5 |
| LT 80 | 120 | | 160 | | | 16 | 6 | 76 | 2.0 | 5 |
| LT 100 | 150 | $\begin{matrix} 0 \\ -0.025 \end{matrix}$ | 185 | | | 20 | 7 | 110 | 2.5 | 5 |

Notes:

- The spline nut accommodates a retainer made of synthetic resin that generates low noise during operation. (There is no high-temperature model for type LT). LT 4 and 5 do not have retainers, so do not remove the shaft from the spline nut, as doing so causes the balls to fall off.
- If a model with seals is required, please specify.
- For model-number coding, see page B-78.

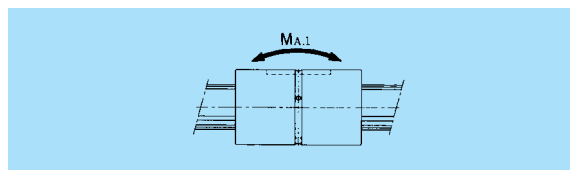

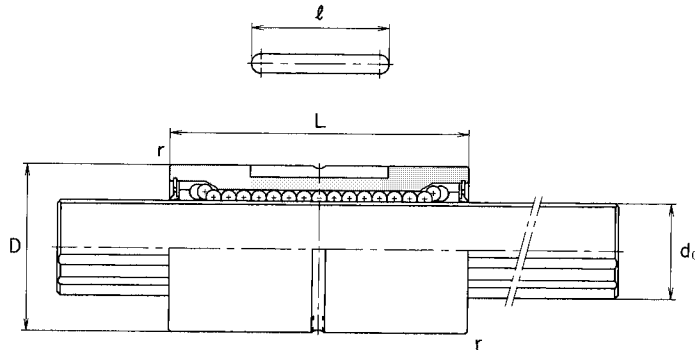

Unit: mm

| Shaft diameter d_0 h7 | No. of trains of balls | Basic load rating | | Basic torque rating | | Static permissible moment | | Mass | |
|-------------------------------|------------------------------|----------------------|-------------|------------------------|----------------|------------------------------|------------------------------|--------------------|-------------------------|
| | | C kN | C_0 kN | C_T Nm | C_{0T} Nm | M_{A1} ¹⁾ Nm | M_{A2} ²⁾ Nm | Spline nut g | Spline shaft kg/m |
| 4 | 4 | 0.44 | 0.61 | 0.59 | 0.78 | 0.88 | 6.4 | 5.2 | 0.10 |
| 5 | 4 | 0.66 | 0.88 | 0.88 | 1.37 | 1.5 | 11.6 | 9.1 | 0.15 |
| 6 | 4 | 1.18 | 2.16 | 0.98 | 1.96 | 4.9 | 36.3 | 17 | 0.23 |
| 8 | 4 | 1.47 | 2.55 | 1.96 | 2.94 | 5.9 | 44.1 | 18 | 0.40 |
| 10 | 4 | 2.84 | 4.90 | 3.92 | 7.84 | 15.7 | 98.0 | 50 | 0.62 |
| 13 | 4 | 3.53 | 5.78 | 5.88 | 10.8 | 19.6 | 138 | 55 | 1.1 |
| 16 | 6 | 7.06 | 12.6 | 31.4 | 34.3 | 67.6 | 393 | 165 | 1.6 |
| 20 | 6 | 10.2 | 17.8 | 56.9 | 55.9 | 118 | 700 | 225 | 2.5 |
| 25 | 6 | 15.2 | 25.8 | 105 | 103 | 210 | 1140 | 335 | 3.9 |
| 30 | 6 | 20.5 | 34.0 | 171 | 148 | 290 | 1710 | 375 | 5.6 |
| 40 | 6 | 37.8 | 60.5 | 419 | 377 | 687 | 3760 | 1000 | 9.9 |
| 50 | 6 | 60.9 | 94.5 | 842 | 769 | 1340 | 7350 | 1950 | 15.5 |
| 60 | 6 | 73.5 | 111.7 | 1220 | 1040 | 1600 | 9990 | 2500 | 22.3 |
| 80 | 6 | 104.9 | 154.8 | 2310 | 1920 | 2510 | 16000 | 4680 | 39.6 |
| 100 | 6 | 136.2 | 195.0 | 3730 | 3010 | 3400 | 24000 | 9550 | 61.8 |

Notes:

- 1) M_{A1} represents the permissible moment in the axial direction when a single spline nut is used, as shown below.
- 2) M_{A2} represents the permissible moment in the axial direction when two closely linked spline nuts are used, as shown below.
(Due to insufficient stability of single spline nut in accuracy, we recommend the use of closely linked double spline nuts.)

Type LF



4-d₁ drill through d₂
spot-facing depth h

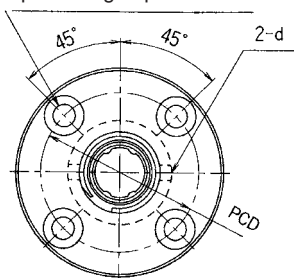

LT13 or lower

4-d, drill through d₂
spot-facing depth h

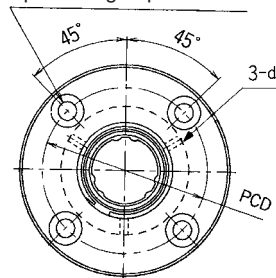

LT16 or higher

| Model No. | Outer diameter | | Length | | Spline-nut dimensions | | | | | | | |
|-----------|----------------|---|--------|---|----------------------------------|---|----|------|------------|-----|----------------------------------|----|
| | D | Tolerance | L | Tolerance | Flange dimensions D ₁ | H | F | C, r | Oil hole d | PCD | Shaft diameter d ₀ h7 | |
| LF 6 | 14 | $\begin{matrix} 0 \\ -0.011 \end{matrix}$ | 25 | $\begin{matrix} 0 \\ -0.2 \end{matrix}$ | 30 | $\begin{matrix} 0 \\ -0.2 \end{matrix}$ | 5 | 7.5 | 0.5 | 1 | 22 | 6 |
| LF 8 | 16 | | 25 | | 32 | | 5 | 7.5 | 0.5 | 1.5 | 24 | 8 |
| LF 10 | 21 | $\begin{matrix} 0 \\ -0.013 \end{matrix}$ | 33 | | 42 | | 6 | 10.5 | 0.5 | 1.5 | 32 | 10 |
| LF 13 | 24 | | 36 | | 44 | | 7 | 11 | 0.5 | 1.5 | 33 | 13 |
| LF 16 | 31 | | 50 | | 51 | | 7 | 18 | 0.5 | 2 | 40 | 16 |
| LF 20 | 35 | $\begin{matrix} 0 \\ -0.016 \end{matrix}$ | 63 | $\begin{matrix} 0 \\ -0.3 \end{matrix}$ | 58 | $\begin{matrix} 0 \\ -0.2 \end{matrix}$ | 9 | 22.5 | 0.5 | 2 | 45 | 20 |
| LF 25 | 42 | | 71 | | 65 | | 9 | 26.5 | 0.5 | 3 | 52 | 25 |
| LF 30 | 47 | | 80 | | 75 | | 10 | 30 | 0.5 | 3 | 60 | 30 |
| LF 40 | 64 | $\begin{matrix} 0 \\ -0.019 \end{matrix}$ | 100 | $\begin{matrix} 0 \\ -0.3 \end{matrix}$ | 100 | $\begin{matrix} 0 \\ -0.2 \end{matrix}$ | 14 | 36 | 1, 0.5 | 4 | 82 | 40 |
| LF 50 | 80 | | 125 | | 124 | | 16 | 46.5 | 1.0 | 4 | 102 | 50 |

Notes:

- The spline nut accommodates a retainer made of synthetic resin that generates low noise during operation. (There is no high-temperature model).
- If a model with seals is required, please specify.
- For model-number coding, see page B-78.

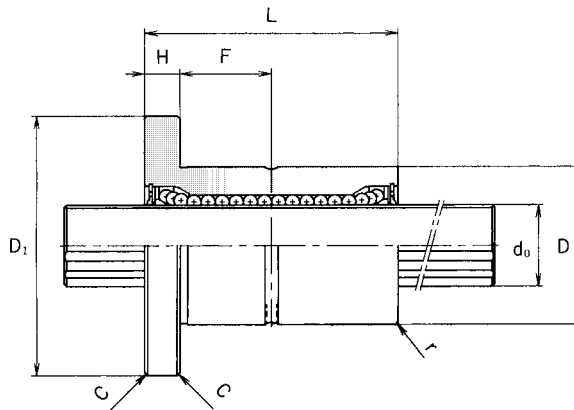

Unit: mm

| No. of trains of balls | Mounting hole $d_1 \times d_2 \times h$ | Basic load rating | | Basic torque rating | | Static permissible moment | | Mass | |
|------------------------|--|-------------------|-------------|---------------------|----------------|---------------------------|----------------------|-----------------|----------------------|
| | | C kN | C_0 kN | C_T Nm | C_{0T} Nm | $M_{A,1}^{1)}$ Nm | $M_{A,2}^{2)}$ Nm | Spline nut g | Spline shaft kg/m |
| 4 | 3.4 × 6.5 × 3.3 | 1.18 | 2.16 | 0.98 | 1.96 | 4.9 | 36.3 | 35 | 0.23 |
| 4 | 3.4 × 6.5 × 3.3 | 1.47 | 2.55 | 1.96 | 2.94 | 5.9 | 44.1 | 37 | 0.40 |
| 4 | 4.5 × 8 × 4.4 | 2.84 | 4.90 | 3.92 | 7.84 | 15.7 | 98 | 90 | 0.62 |
| 4 | 4.5 × 8 × 4.4 | 3.53 | 5.78 | 5.88 | 10.8 | 19.6 | 138 | 110 | 1.1 |
| 6 | 4.5 × 8 × 4.4 | 7.06 | 12.6 | 31.4 | 34.3 | 67.6 | 393 | 230 | 1.6 |
| 6 | 5.5 × 9.5 × 5.4 | 10.2 | 17.8 | 56.9 | 55.9 | 118 | 700 | 330 | 2.5 |
| 6 | 5.5 × 9.5 × 5.4 | 15.2 | 25.8 | 105 | 103 | 210 | 1140 | 455 | 3.9 |
| 6 | 6.6 × 11 × 6.5 | 20.5 | 34.0 | 171 | 148 | 290 | 1710 | 565 | 5.6 |
| 6 | 9 × 14 × 8.6 | 37.8 | 60.5 | 419 | 377 | 687 | 3760 | 1460 | 9.9 |
| 6 | 11 × 17.5 × 11 | 60.9 | 94.5 | 842 | 769 | 1340 | 7350 | 2760 | 15.5 |

Notes:

- 1) $M_{A,1}$ represents the permissible moment in the axial direction when a single spline nut is used, as shown below.
- 2) $M_{A,2}$ represents the permissible moment in the axial direction when two closely linked spline nuts are used, as shown below.

(Due to insufficient stability of single spline nut in accuracy, we recommend the use of closely linked double spline nuts.)

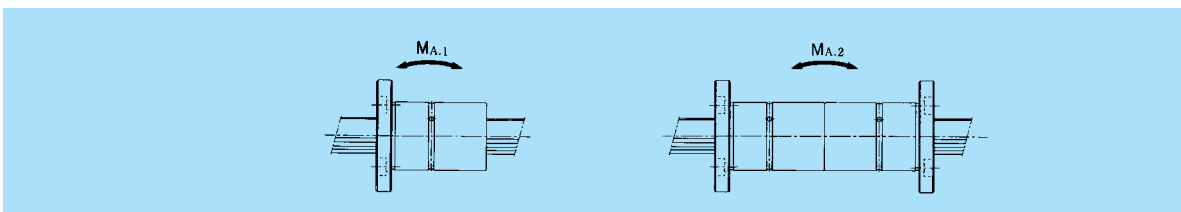

Recommended Type-LT Spline-Shaft End Shape

(for support)

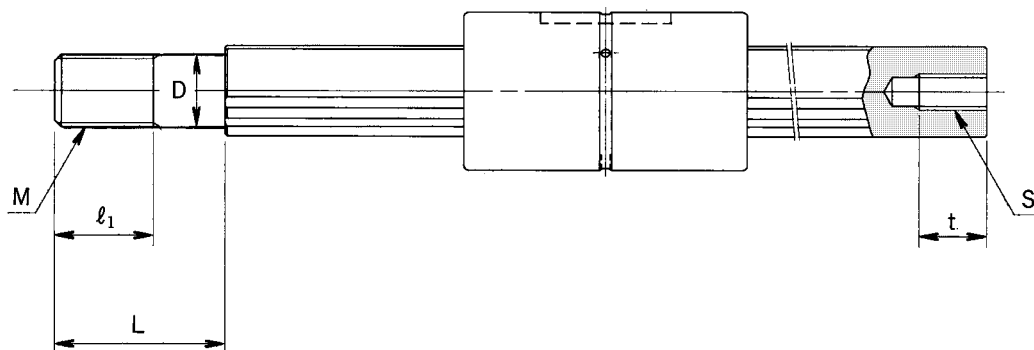

Unit : mm

| Model No. | D | Tolerance | L | M | l_1 | S × t |
|-----------|----|-------------|-----|------------|-------|-----------|
| LT 6 | 5 | 0 -0.012 | 12 | M 5 × 0.8 | 7 | M 2.5 × 4 |
| LT 8 | 6 | | 14 | M 6 × 1.0 | 8 | M 3 × 5 |
| LT 10 | 8 | 0 -0.015 | 18 | M 8 × 1.0 | 11 | M 4 × 6 |
| LT 13 | 10 | | 23 | M10 × 1.25 | 14 | M 5 × 8 |
| LT 16 | 14 | 0 -0.018 | 30 | M14 × 1.5 | 18 | M 6 × 10 |
| LT 20 | 16 | | 38 | M16 × 1.5 | 22 | M 8 × 15 |
| LT 25 | 22 | 0 -0.021 | 50 | M22 × 1.5 | 28 | M 10 × 18 |
| LT 30 | 27 | | 60 | M27 × 2.0 | 34 | M 14 × 25 |
| LT 40 | 36 | 0 -0.025 | 80 | M36 × 3.0 | 45 | M 18 × 30 |
| LT 50 | 45 | | 100 | M45 × 4.5 | 58 | M 22 × 40 |